

FAN AND MOTOR BASE
SCALE 1 / 4

PARTS LIST				
ITEM	QTY	PART NUMBER	MATERIAL	DESCRIPTION
1	1	I-BEAM 1	WELDED ALUMINUM	
2	1	I-BEAM 2	WELDED ALUMINUM	
3	1	I-BEAM 3	WELDED ALUMINUM	
4	1	I-BEAM 4	WELDED ALUMINUM	
5	1	I-BEAM 5	WELDED ALUMINUM	
6	4	SPRING PLATE BASE	WELDED ALUMINUM	SUB ASSEMBLY
7	8	SIDE PLATE	WELDED ALUMINUM	
8	4	BACK PLATE	WELDED ALUMINUM	
9	4	TOP PLATE	WELDED ALUMINUM	
10	4	WELDED SPRING PLATE	WELDED ALUMINUM	SUB ASSEMBLY
11	4	COIL	STEEL	
12	4	FOOT TOP	WELDED ALUMINUM	
13	4	FOOT BOTTOM	STIFF RUBBER	
14	4	HEX BOLT 120MM	STEEL	
15	4	HEX NUT 12	STEEL	
16	4	FOOT ASSEMBLY		SUB ASSEMBLY
17	4	COIL PLATE WELD ASSEMBLY		SUB ASSEMBLY
18	1	FOOT PAD		SUB ASSEMBLY

ALL I-BEAMS ARE S100 X 14.1

DIGITAL DESIGN GRAPHIC TECHNOLOGY 121	NAME:	J.VALADAO	FAN AND MOTOR BASE FIG18-50	1 OF 6
	COURSE:	DDGT 121		
	DATE:	4/14/2011		

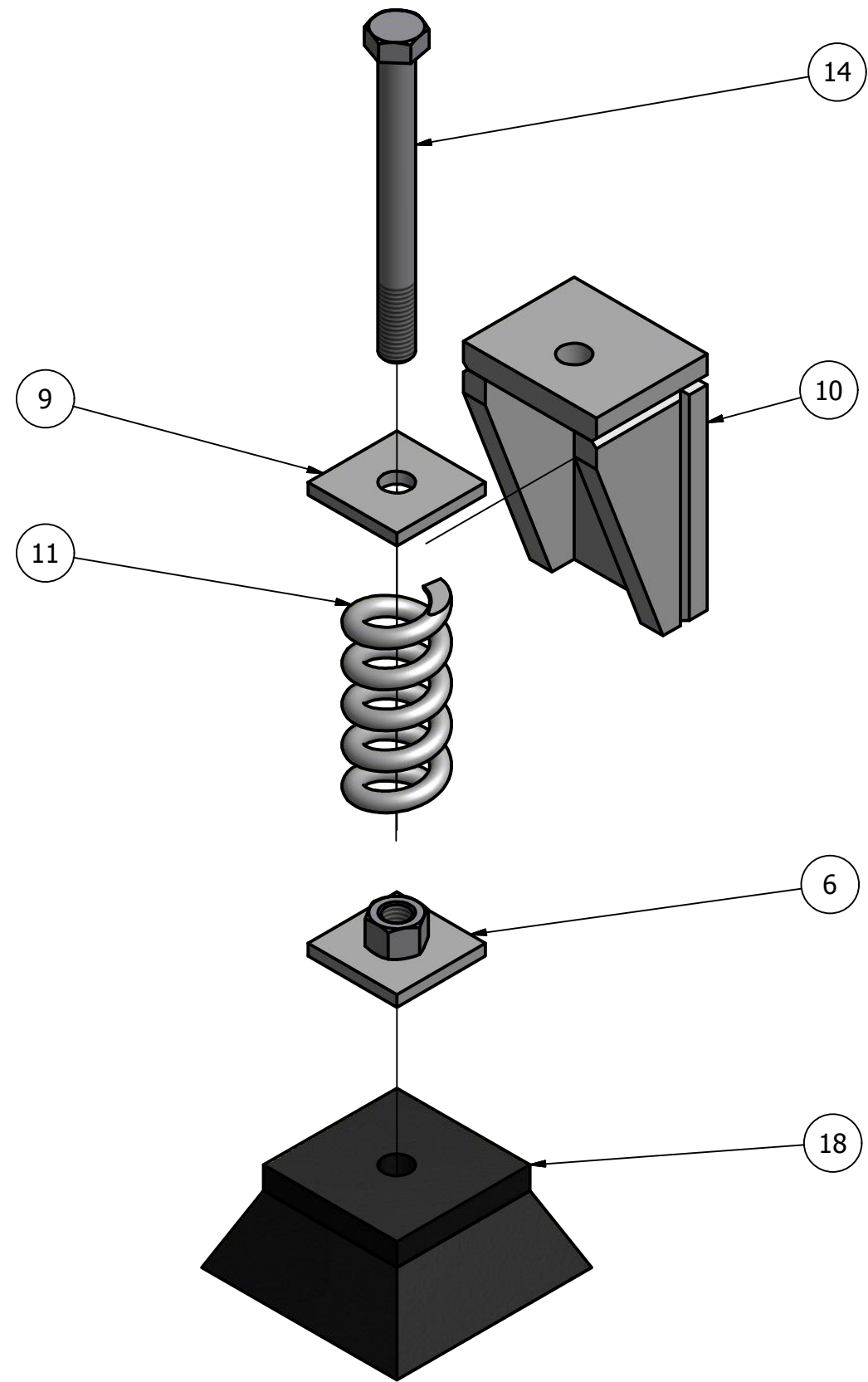

FOOT EXPLODED ASSEMBLY
SCALE 1 / 2

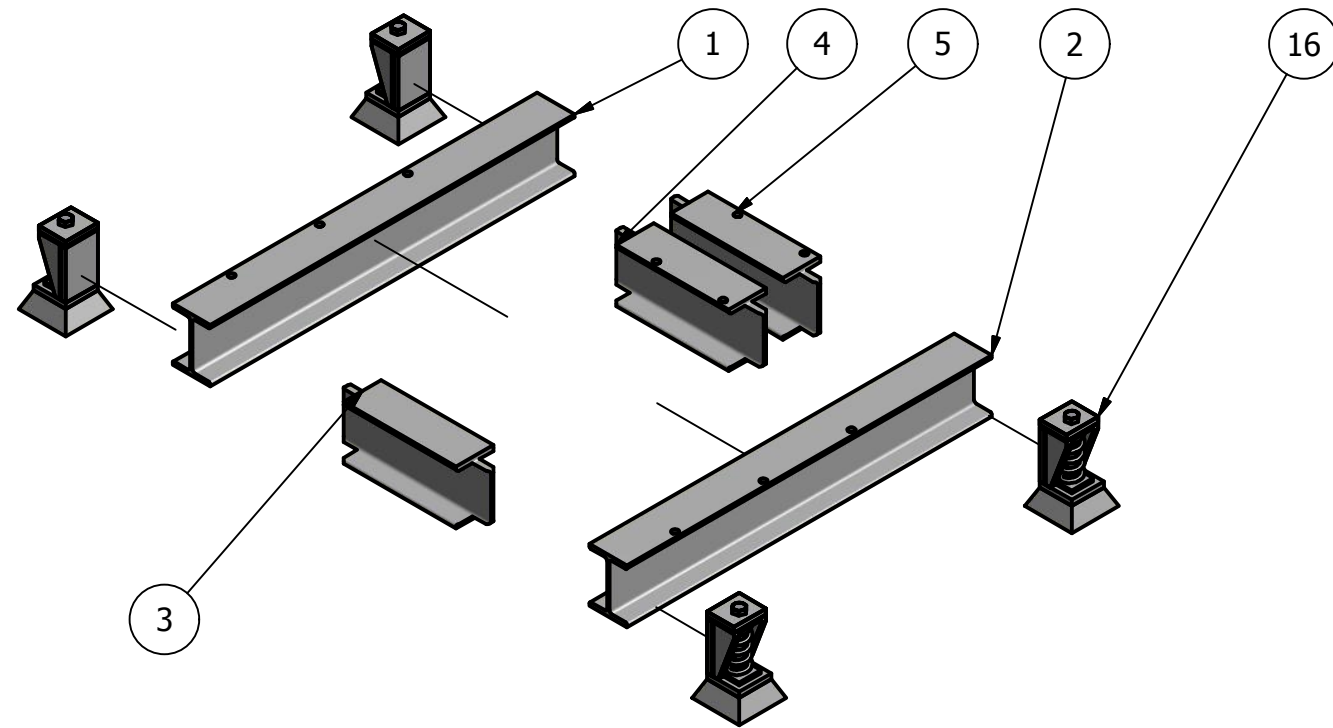

EXPLODED BASE ASSEMBLY
SCALE 1 / 10

PARTS LIST		
ITEM	QTY	PART NUMBER
1	1	I-BEAM 1
2	1	I-BEAM 2
3	1	I-BEAM 3
4	1	I-BEAM 4
5	1	I-BEAM 5
6	4	SPRING PLATE BASE
9	4	TOP PLATE
10	4	WELDED SPRING PLATE
11	4	COIL
14	4	HEX BOLT 120MM
15	4	HEX NUT 12
16	4	FOOT ASSEMBLY
17	4	COIL PLATE WELD ASSEMBLY
18	1	FOOT PAD

DIGITAL DESIGN GRAPHIC TECHNOLOGY 121	NAME:	J.VALADAO	FAN AND MOTOR BASE FIG18-50	2 OF 6
	COURSE:	DDGT 121		
	DATE:	4/14/2011		

PARTS LIST		
ITEM	QTY	PART NUMBER
1	1	I-BEAM 1
2	1	I-BEAM 2
3	1	I-BEAM 3
4	1	I-BEAM 4
5	1	I-BEAM 5
18	1	FOOT PAD

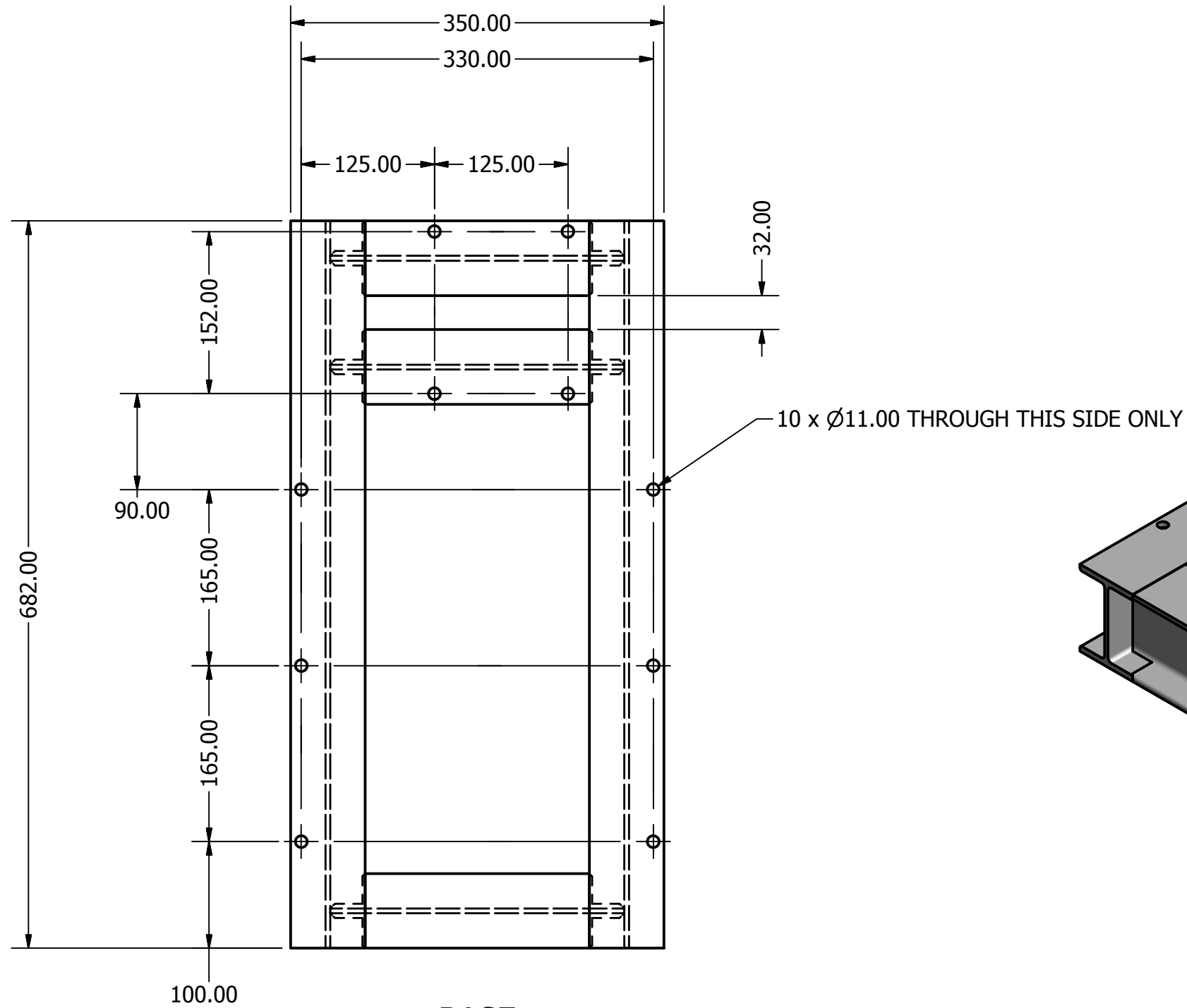

BASE
SCALE 1 / 5

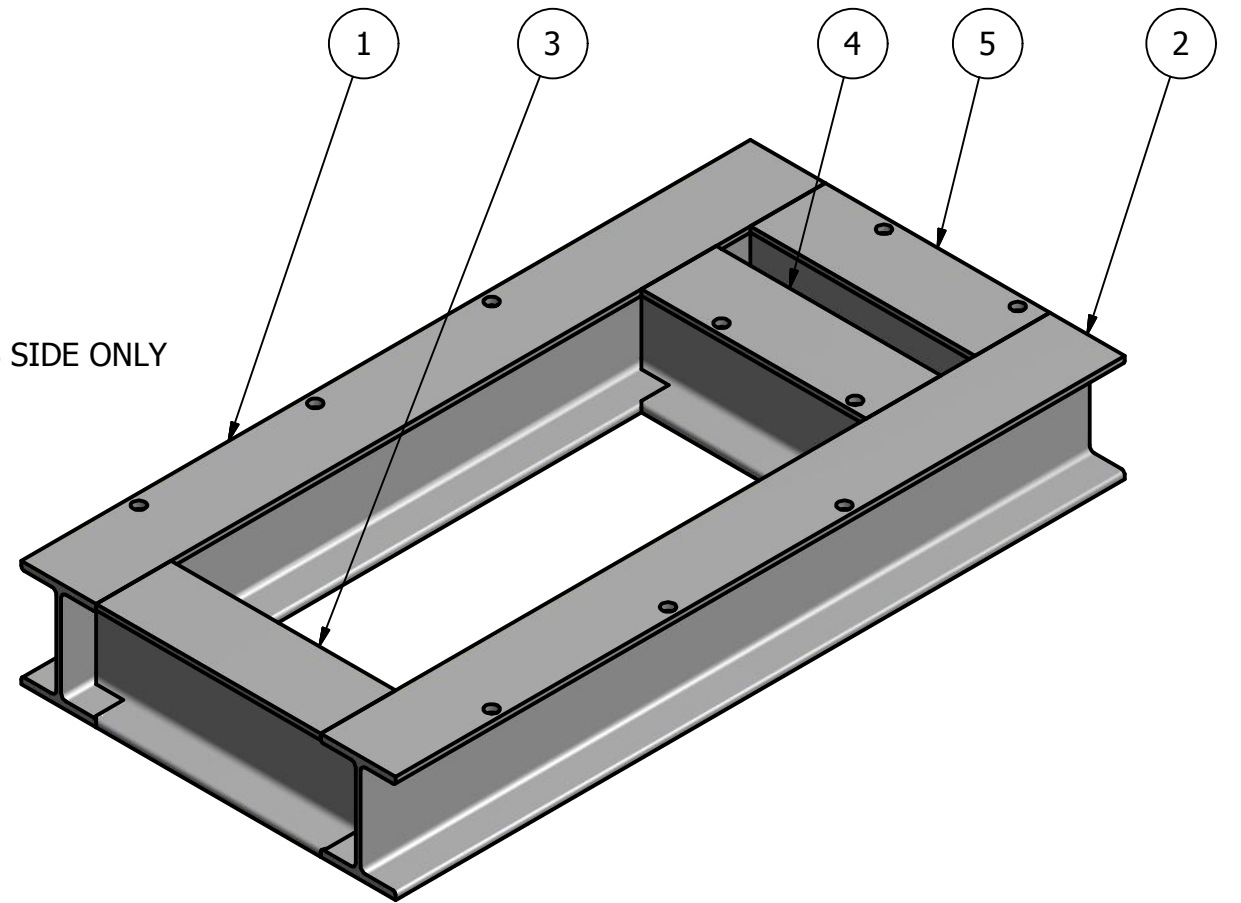

DIGITAL DESIGN GRAPHIC TECHNOLOGY 121	NAME:	J.VALADAO	FAN AND MOTOR BASE FIG18-50	3 OF 6
	COURSE:	DDGT 121		
	DATE:	4/14/2011		

PARTS LIST		
ITEM	QTY	PART NUMBER
1	1	I-BEAM 1
2	1	I-BEAM 2
3	1	I-BEAM 3
4	1	I-BEAM 4
5	1	I-BEAM 5
18	1	FOOT PAD

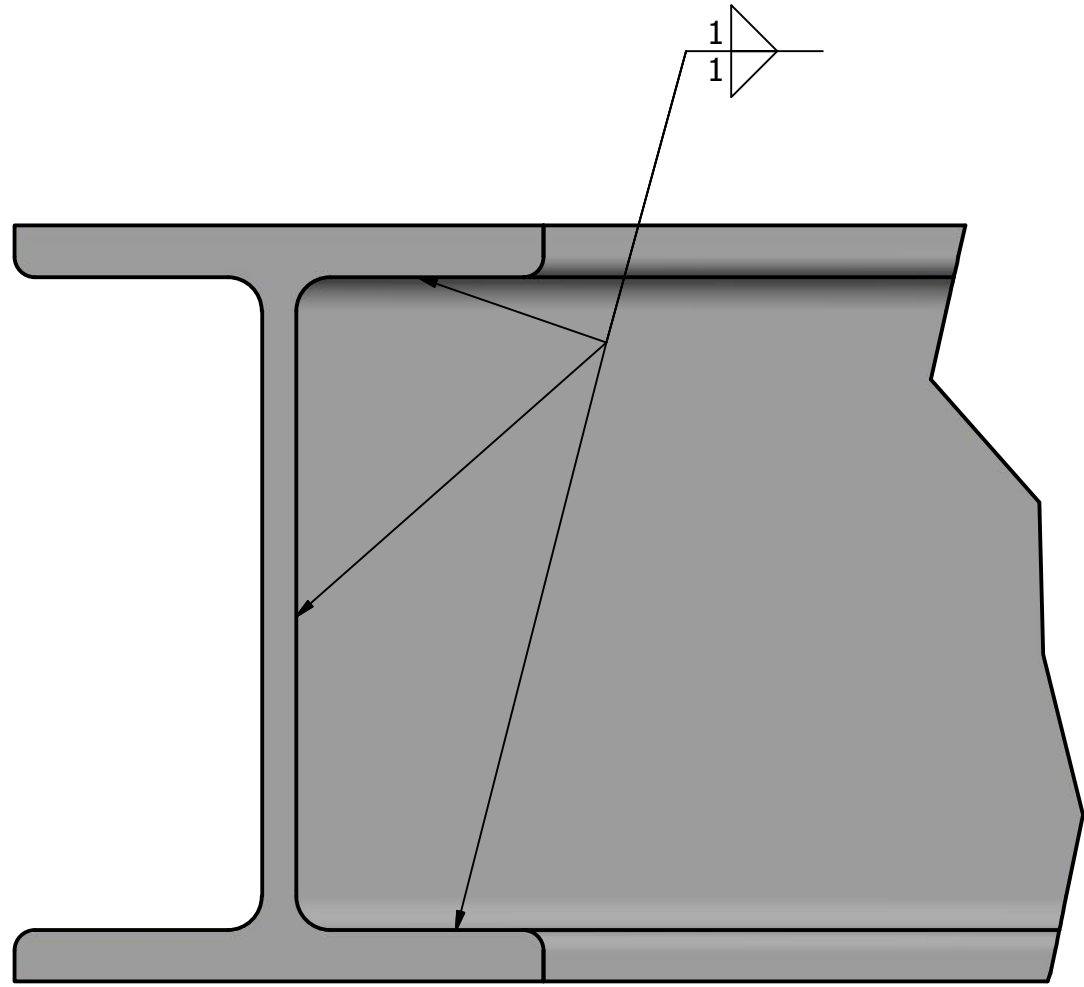

DETAIL A
SCALE 1 / 1

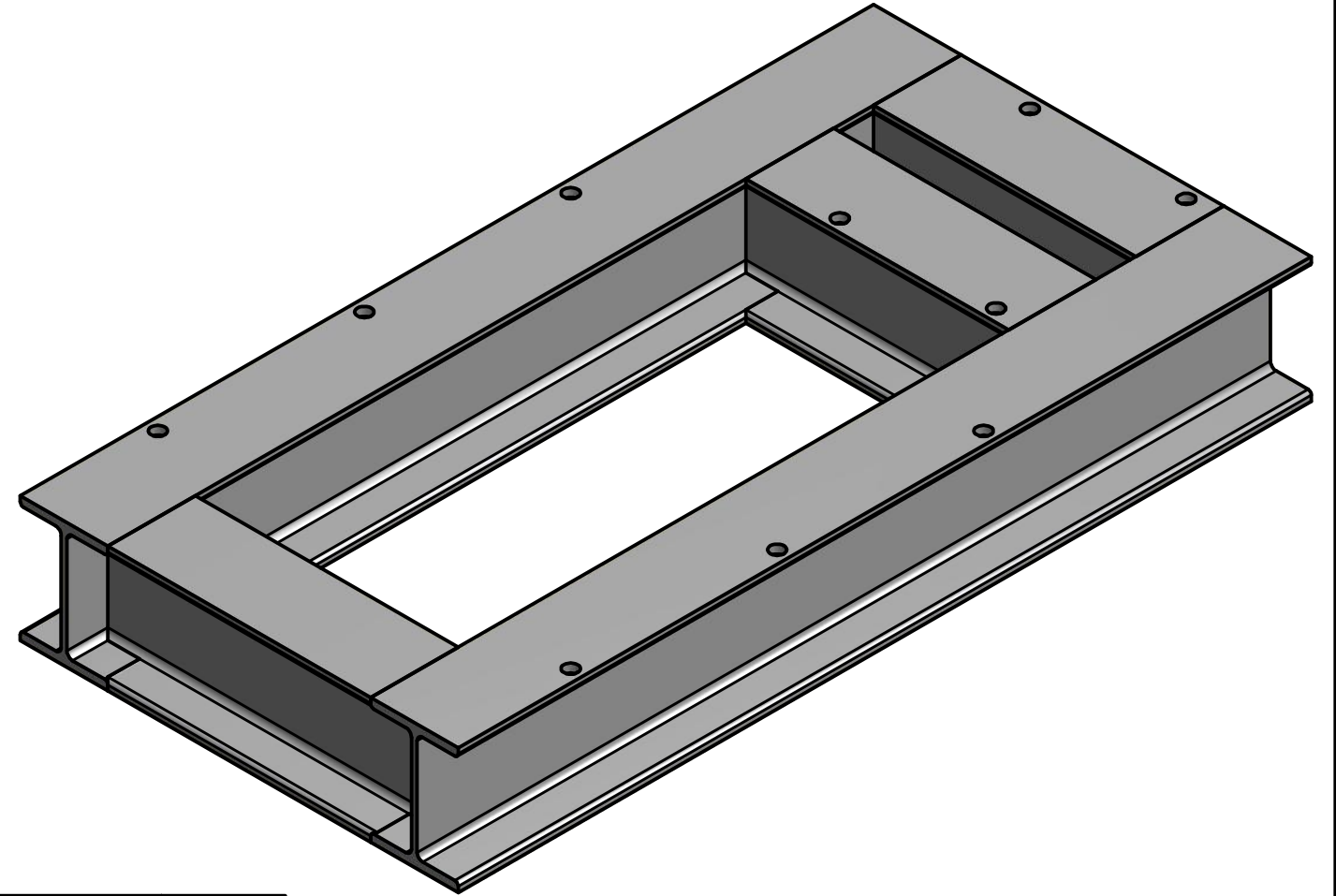

ALL WELDS ON "FAN MOTOR BASE" ASSEMBLY ARE THE SAME ON SIX LOCATIONS.

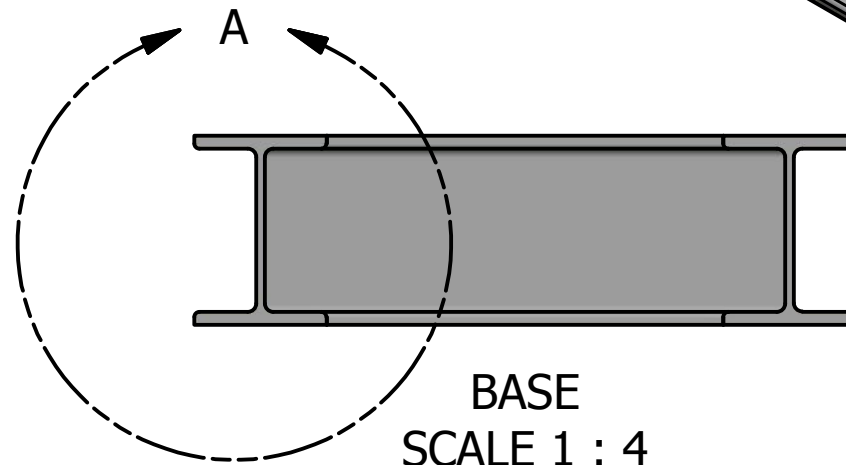

BASE
SCALE 1 : 4

DIGITAL DESIGN GRAPHIC TECHNOLOGY 121	NAME:	J.VALADAO	FAN AND MOTOR BASE FIG18-50	4 OF 6
	COURSE:	DDGT 121		
	DATE:	4/14/2011		

PARTS LIST		
ITEM	QTY	PART NUMBER
7	8	SIDE PLATE
8	4	BACK PLATE
9	4	TOP PLATE
10	4	WELDED SPRING PLATE
18	1	FOOT PAD

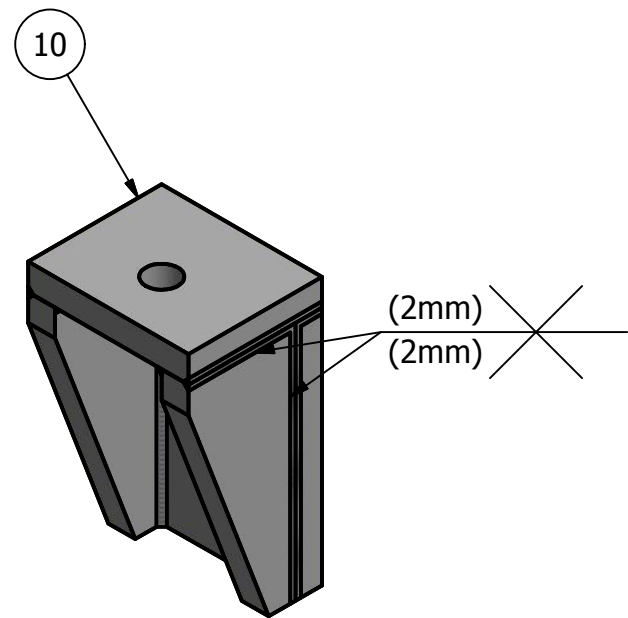

WELDED SPRING PLATE
SCALE 1 / 2

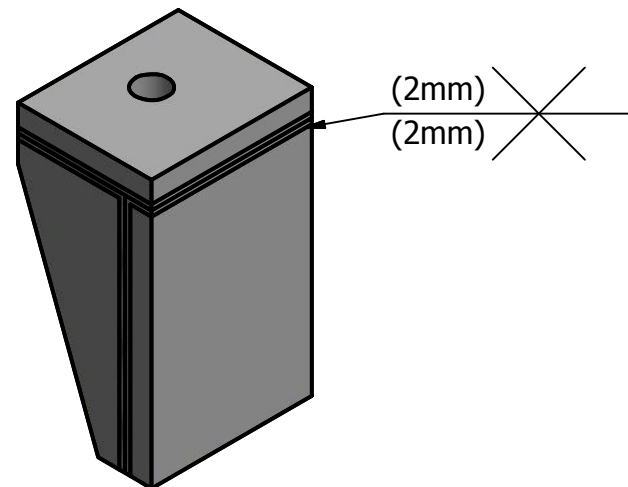

BACK PLATE
SCALE 1 / 2

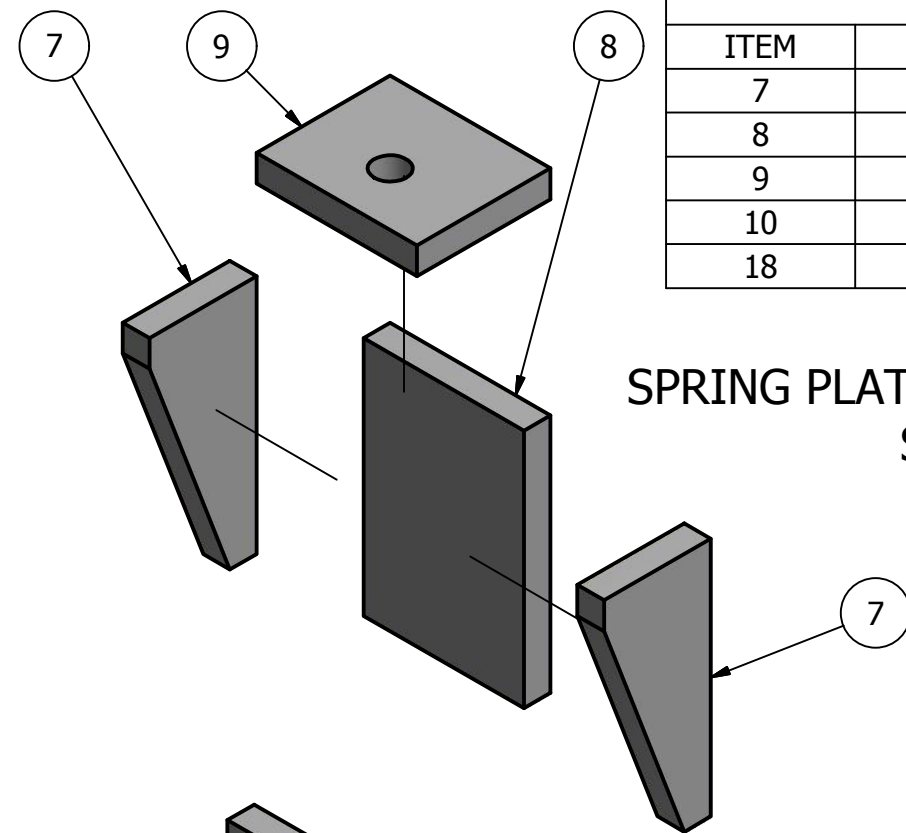

SPRING PLATE EXPLODED ASSEMBLY
SCALE 1 / 2

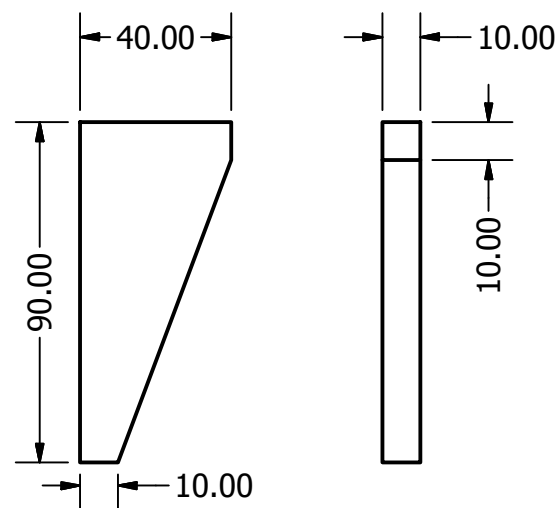

SIDE PLATE
SCALE 1 / 2

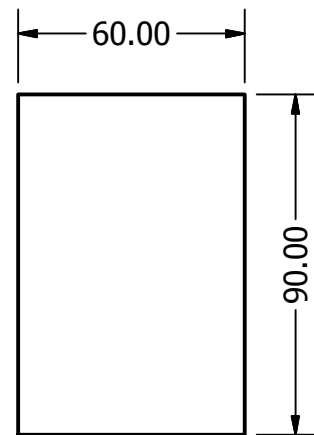

TOP PLATE
SCALE 1 / 2

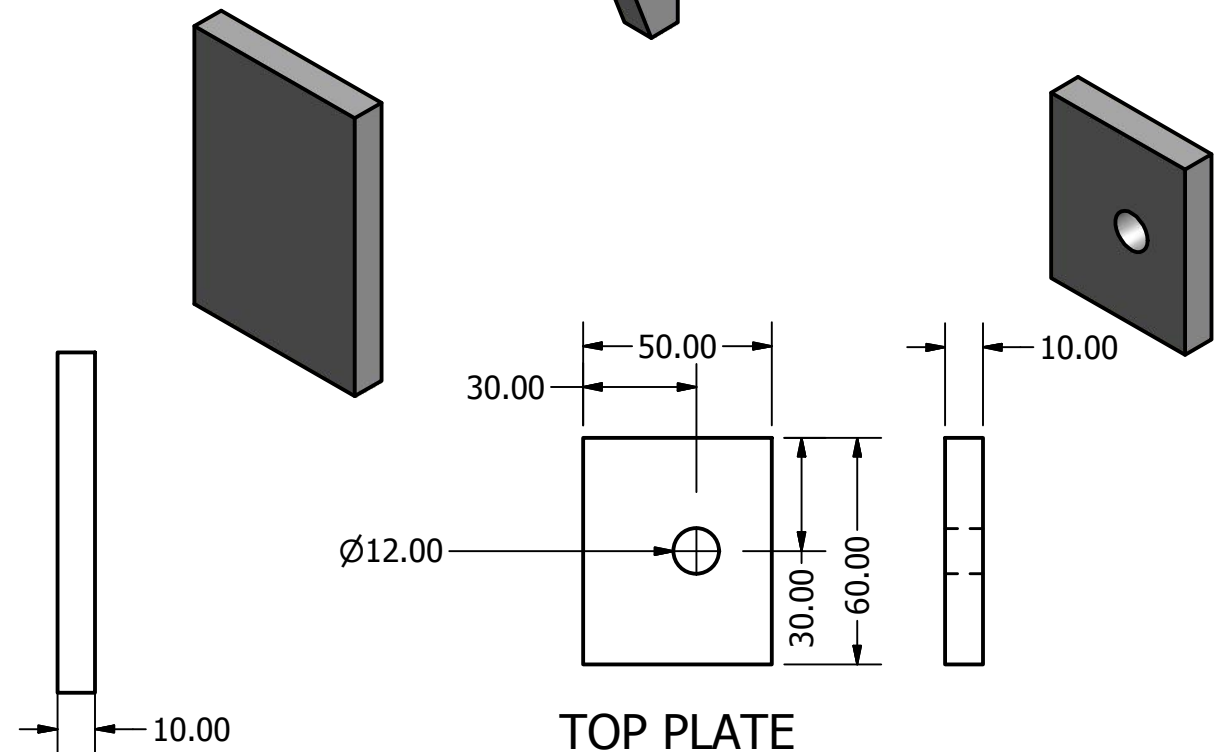

DIGITAL DESIGN GRAPHIC TECHNOLOGY 121	NAME:	J.VALADAO	FAN AND MOTOR BASE FIG18-50	5 OF 6
	COURSE:	DDGT 121		
	DATE:	4/14/2011		

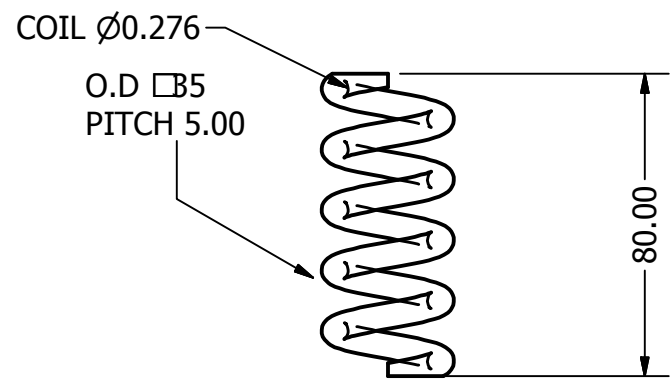

COIL
SCALE 1 / 2

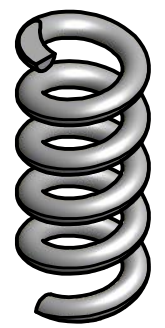

PARTS LIST		
ITEM	QTY	PART NUMBER
6	4	SPRING PLATE BASE
10	4	WELDED SPRING PLATE
11	4	COIL
15	4	HEX NUT 12
17	4	COIL PLATE WELD ASSEMBLY
18	1	FOOT PAD

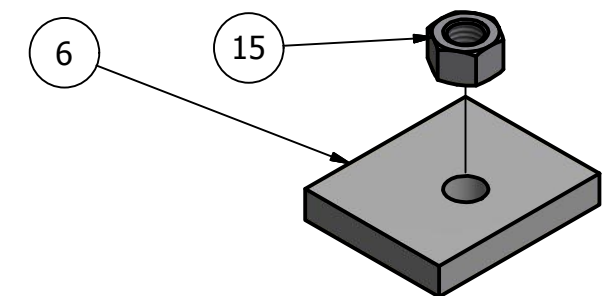

COIL PLATE EXPLODED ASSEMBLY
SCALE 1 / 2

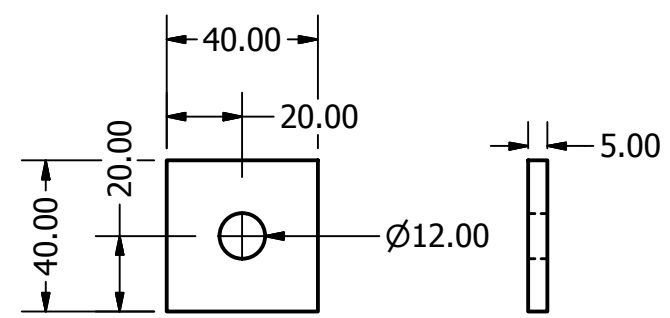
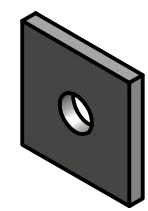

SPRING PLATE
SCALE 1 / 2

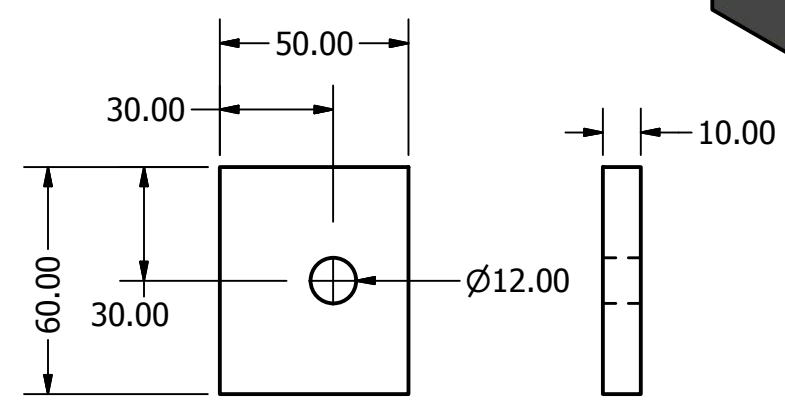
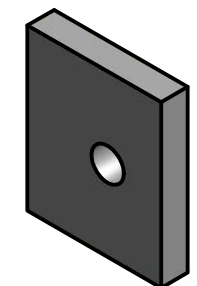

SPRING PLATE BASE
SCALE 1 / 2

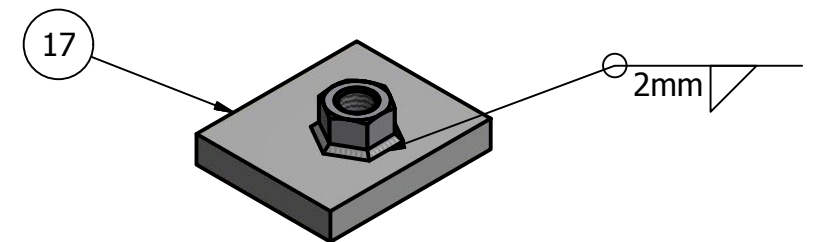

COIL PLATE WELD ASSEMBLY
SCALE 1 / 2

DIGITAL DESIGN GRAPHIC TECHNOLOGY 121	NAME:	J.VALADAO	FAN AND MOTOR BASE FIG18-50	6 OF 6
	COURSE:	DDGT 121		
	DATE:	4/14/2011		